

Altair Inspire Extrude

Metal and Polymer Extrusion Process

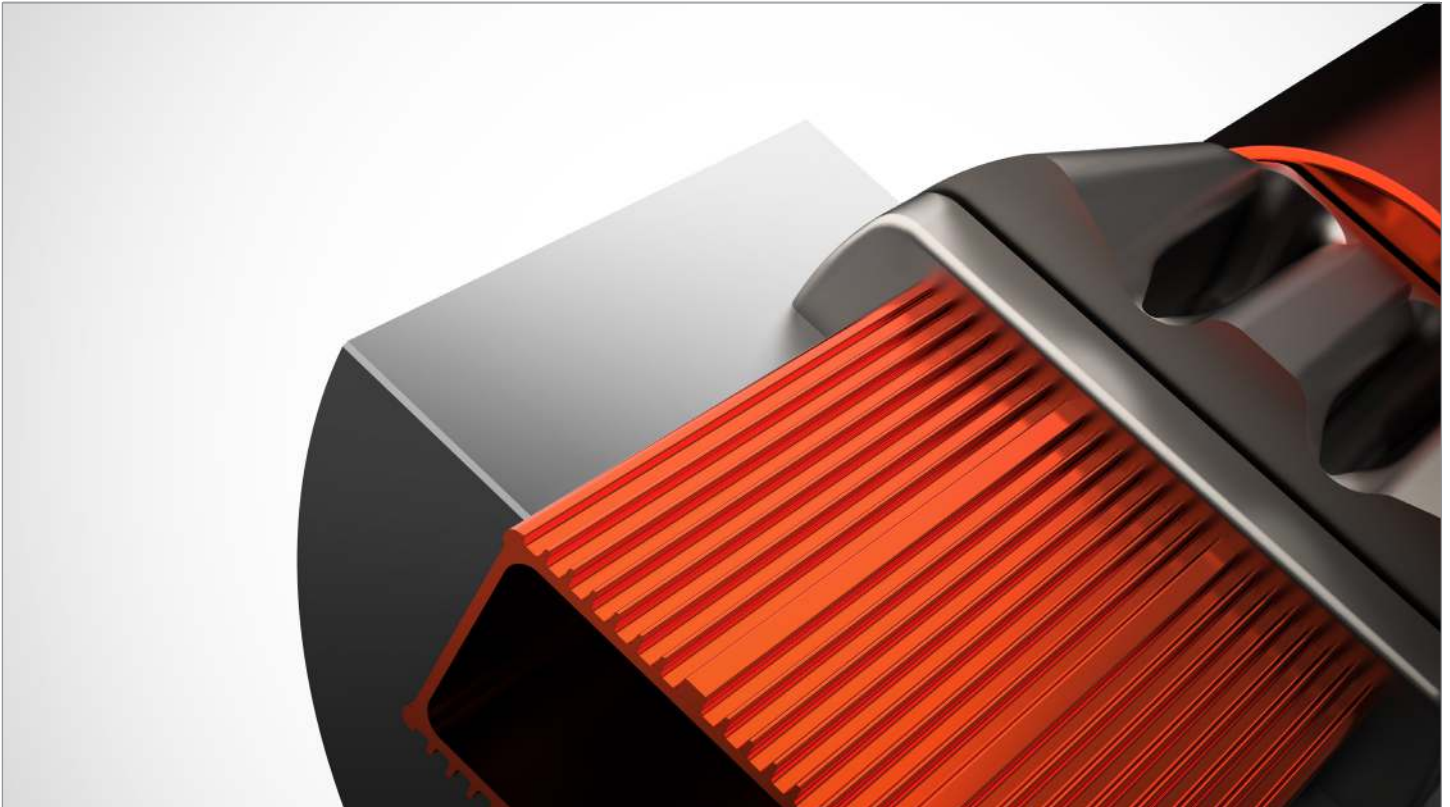

Altair Inspire Extrude is a simulation environment designed to help extrusion companies meet the ever increasing demands to produce complex profiles with tight tolerances, quality surface finishes, and high strength properties at reduced cost. Inspire Extrude is a virtual press where users can visualize material flow and temperature inside a die during extrusion and make necessary changes to ensure balanced flow, while identifying and eliminating product defects.

Product Highlights

- Test and validate new die designs
- Improve productivity
- Optimize/correct die designs and process conditions
- Determine product quality
- Automated, easy to learn, extrusion-specific user interface

Benefits

Validate and Correct Die Design

Use Inspire Extrude simulations to understand and improve the performance of a die from multiple perspectives (nose cone, product quality, weld strength, process efficiency).

Extrude New Alloys

Flow stress and material behavior of new alloys requires an accurate simulation. Inspire Extrude can handle a wide range of alloys.

Determine Die Stresses and Failure

Inspire Extrude together with Altair OptiStruct™ is used to determine tool deflection, mandrel shift, stress concentrations, and potential early die failure.

Increase Productivity

Inspire Extrude is used to optimize ram speed, billet preheat, and billet taper heating to improve productivity and reduce cost.

Increase Recovery and Reduce Scrap

To minimize front and back scrap, the weld length can be computed and the skin material of the billet entering the product can be tracked. Altair Inspire Extrude can optimize the billet length to reduce the scrap considering all aspects of extrusion and fabrication.

Determine Product Quality

Product quality can be improved by eliminating extrusion defects and the effects of die deflection on the product shape. By determination of seam weld location and strength, grain size and yield strength the product quality is further assessed.

Quenching Analysis

Quenching the extruded profile is crucial for controlling grain size and mechanical properties of the profile. Quenching analysis is used to predict the cooling rate, temperature, and uniformity of cooling during the process.

Learn more:
altair.com/inspire-extrude

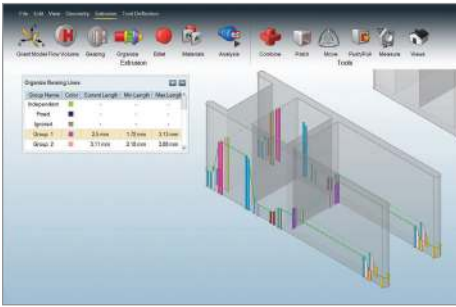

Bearing optimization

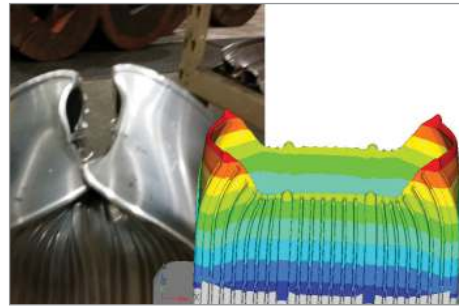

Experimental validation of a test case

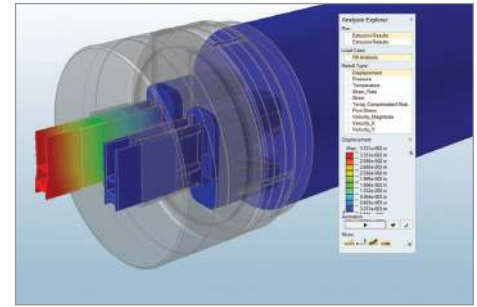

Extrusion result visualization

A Complete Solution For Die Design Engineers

- Test and validate new die designs
- Determine correct bearing lengths
- Adjust porthole and pocket dimensions
- Predict die deflection, stresses, and failure

Simulation Engineers

- Troubleshoot problem dies
- Improve productivity
- Predict product quality

Production Engineers

- Optimize process conditions
- Manage extrusion inventory
- Reduce scrap and maximize recovery
- Prepare cost estimates and quotations
- Determine the performance of quench system

Quality Engineers

- Determine product quality
- Predict grain size and recrystallization
- Calculate yield strength

Capabilities

Inspire Extrude comes with powerful and complete features that enable an extrusion engineer to optimize the die and improve product quality in the design stage before going into the first die trial.

Support for all Die Types

- Solid, semi-hollow, and hollow profiles
- Multi-hole dies
- Feeder plates and spreader dies
- Direct, indirect, conform, and co-extrusion processes

Product Quality and Defects

- Predict profile shape and nose cone
- Predict surface defects
- Predict the location and quality of seam welds
- Determine transverse weld length

- Track surface impurities and determine when they enter the profile
- Predict grain size and yield strength of the profile

Thermal Management

- Simulate coupled flow and thermal solution
- Determine optimum billet preheat and taper
- Determine temperature changes in tool between different extrusion cycles

Virtual Die Trials

- Visualize material flowing through the die passages
- Determine causes for flow imbalance and overheating
- Study responses to design changes

Tool Deflection Analysis

- Simulate coupled flow, thermal, and stress analysis
- Calculate die deflection and mandrel shift during extrusion
- Minimize tool deflection to meet product tolerances
- Identify causes for tool breakage
- Optimize the shape and size of dummy block, backers, and bolsters

Super Alloy Extrusion

- Simulate glass lubrication
- Predict glass pad erosion
- Compute lubrication effectiveness

Quench Analysis

- Supports for press and solution quenching
- Analyze different quenching types
- Quench factor analysis
- Compute temperature history and cooling rate during quenching

Comprehensive Material Database

- Database of commonly used alloys
- Fit flow stress model

- Based on extrudability number
- From flow stress table data
- Material models using user defined subroutines

Contact Friction

- Viscoplastic friction model
- Coulomb friction model
- Slip velocity model

Optimize Die Design

- Accurate and easy to use bearing length correction module
- Modify pocket and porthole dimensions

Extrusion System Management

- Calculate optimum process conditions
- Determine best press to increase productivity
- Optimize billet length to reduce scrap
- Estimate costs
- Prepare quotations

Results

- Profile deformation and nose cone
- Extrusion load
- Seam weld locations and strength
- Transverse weld length
- Billet skin tracking
- Particle traces and velocity vectors
- Temperature distribution
- Strain and strain rate
- Flow stress
- Stress tensor
- Tool deflection and stresses
- Product quality:
 - Grain size
 - Yield strength
 - Surface quality
- User defined results
- Glass lubrication effectiveness
- Quench Analysis:
 - Cooling Rate
 - Quench Factor